

# **SSP-885-2 ENGINE MOUNTED OIL FILTER KITS AND REPLACEMENT FILTERS**

## **NOTE**

This Special Service Publication (SSP) supersedes SSP-885-1 dated February 1988.

## **INTRODUCTION**

Clean engine oil is essential to long engine life. Full-flow filter elements and full-flow spin-on assemblies are an added improvement over older methods of filtration and can be installed on any applicable engine not equipped with a filter.

Installing an oil filter on an engine not equipped with a filter can increase the oil change interval from 25 to 50 hours.

**MODELS AFFECTED:** All Lycoming Direct Drive and TIGO-541 reciprocating engines.

**TIME OF COMPLIANCE:** As required.

PART I – Preparations for Installing an Oil Filter

PART II – Installation of the Full-Flow Oil Filter Assembly Kit P/N LW-14089

PART III – Installation of the Spin-On Oil Filter Assembly

PART IV – Approved Replacement Oil Filters and Element Kits

This page intentionally left blank.

Engines not equipped with an oil filter can be converted as shown in Figures 2, 3, 4 and 5. The filter is mounted on the oil pressure screen housing pad by means of a special adapter which also serves as a housing for the thermostatic oil cooler bypass valve and oil temperature bulb. See Figure 1 for required clearance between the accessory housing mounting pad and the aircraft firewall.

NOTE

No oil filter adapter is required on engines incorporating a dual magneto type accessory housing. The filter is mounted on the right side of the accessory housing in an integrally cast and machined pad. See Figure 5.

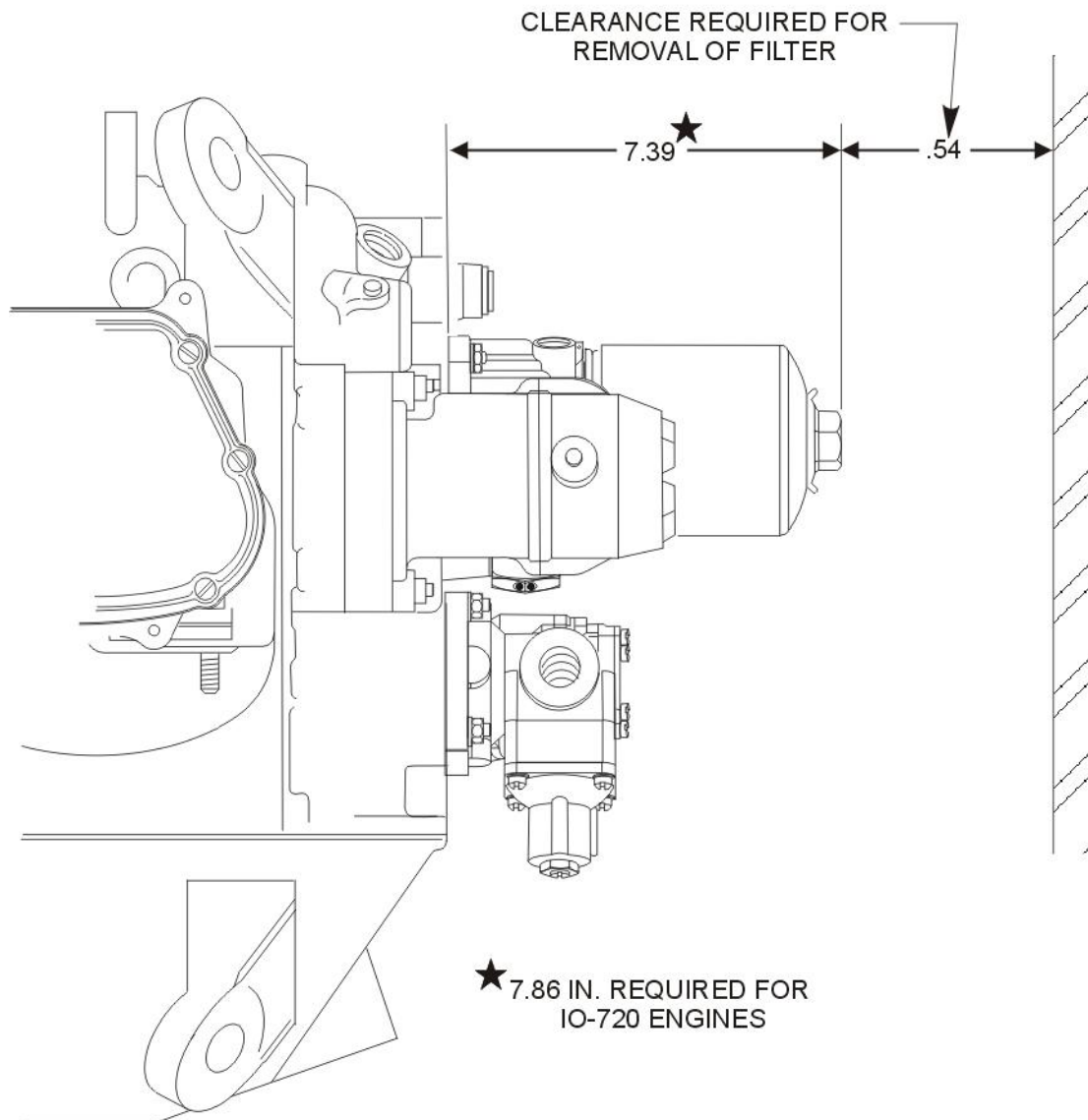

Figure 1. Full-Flow Oil Filter Installation  
Rear of Engine, Side View

**PART I – PREPARATION FOR INSTALLING AN OIL FILTER**

Installation of the new filter is accomplished as follows:

1. Remove the oil temperature bulb from the end of the oil pressure screen housing. Also, remove the thermostatic bypass valve if the engine is equipped with one.
2. If necessary, remove the left magneto to provide sufficient clearance for removal of the oil pressure screen housing and installation of a new filter and adapter.
3. Remove the four capscrews and washers that attach the oil pressure screen housing to the engine. Remove the screen housing and gasket. If any portion of the gasket adheres to the mounting surface of the accessory housing, remove it completely and clean the mounting surface with Methyl-Ethyl-Ketone, Acetone, Napasco SC-200, M17 or M114 solvent before the new gasket is installed.
4. If the engine was not equipped with a thermostatic bypass valve, remove the plug located above the oil filter mounting pad and remove the spring and plunger that serve as an oil cooler bypass valve. Reinstall the plug and gasket. See Figures 2 and 3. Remove the oil cooler adapter on 76 series models. The full-flow filter base contains all provisions for oil cooler operation; therefore, the adapter is no longer necessary. See Figure 4.

**NOTE**

The above step 4 does not apply to some installations of the O-235 and O-290 which have no provision for an oil cooler. See Figure 8 for models not using full-flow canister type oil filter, but utilizing oil cooler adapter P/N 62418.

5. Using a ¼ inch stud driver, install a P/N 25C-10-P03 stud (P/N 25C-14-P03 on IO-720 engines) in the lower left tapped hole in the accessory housing mounting pad. See Figures 2 and 3. Drive the stud to a height of .64/.68 on O-235-C models; 1.08/1.12 on IO-720 models and .60/.64 on all other engine models. On 76 series models, first remove the two original studs from the oil filter pad, then install three P/N 25C-10-P03 studs (1 each) at the lower left, upper left and upper right mounting pad holes. See Figure 4. Driven height on these studs is .59/.63.
6. Before installing the three P/N STD-1856 ¼ inch capscrews (use P/N STD-2153 screws on IO-720 models), check the depth of the tapped holes in the mounting pad by turning the capscrews into the holes by hand, as far as they will go. Measure the distance between the pad and the underside of the screwhead. If the distance is more than ¼ inch, retap the hole using a ¼-20 bottoming tap to clean the threads in the bottom of the hole.
7. Assemble a P/N LW-12795 adapter gasket (use P/N LW-12776 gasket on IO-720 models, P/N LW-15046 on 76 series models), on the oil filter adapter mounting pad. Use POB or an equivalent gasket sealant. Note that the installation directions for these gaskets are printed on the gasket surface. Gaskets incorporating the words “OIL FILTER SIDE” must be installed with the wording facing the oil filter adapter. Gaskets incorporating the wording “ACC. HSG. SIDE” must be installed with the wording facing the accessory housing. The top of the gaskets are also marked either “TOP OF ENGINE” or “THIS EDGE TOWARD TOP OF ENGINE”.

**CAUTION**

P/N 76691 GASKET, SUPERSEDED BY P/N LW-12795 GASKET MAY BE USED ON ALL ENGINES EXCEPT THE O-235, 76 SERIES AND IO-720 SERIES. P/N LW-12795 GASKET MUST BE USED ON O-235 ENGINES; P/N LW-15046 GASKET ON 76 SERIES ENGINES AND P/N LW-12776 GASKET ON IO-720 ENGINES.

8. On O-235 series only, assemble the P/N LW-12999 plate and a second P/N LW-12795 gasket as indicated in Figure 2. On IO-720 engines use P/N LW-12775 plate and P/N LW-12777 gasket; note lettering on gasket and assemble accordingly. See Figure 3.
9. Install the P/N 77852 adapter assembly on the accessory mounting pad and secure it with a P/N STD-8 plain washer, STD-160 internal tooth lockwasher and P/N STD-1411 nut over the stud in the lower left corner of the mounting pad. Use P/N LW-15047 adapter on 76 series models and attach with three P/N STD-8 washers, three P/N STD-160 washers and three P/N STD-1411 nuts. (If there is not enough clearance between the end of the stud and the adapter to install the nut, remove the adapter assembly and drive the stud one additional turn.) Also, after tightening the nut, make sure the end of the stud does not interfere with the adapter.

**PART I – PREPARATION FOR INSTALLING AN OIL FILTER (CONT.)**

10. Use the three P/N LW-25-1.00 hex head bolts to finish attaching the adapter to the mounting pad. Use P/N STD-8 plain washers between the adapter and the lockwasher P/N STD-160. On the IO-720 use three P/N STD-2153 bolts, three P/N STD-160 lockwashers and three P/N STD-8 plain washers. The 76 series models use one P/N LW-25-3.00 bolt, one P/N STD-160 lockwasher and one P/N STD-8 plain washer.
11. Tighten the bolts and nuts installed in steps 9 and 10 to 75 inch pounds torque.
12. If the magneto has been removed, reinstall it and retune the magneto to the engine.

**PART II – INSTALLATION OF LYCOMING APPROVED FULL-FLOW OIL FILTER ASSEMBLY PART NUMBER LW-14089**

1. Make sure the adapter gasket and housing gasket are correctly seated; then check the nylon nut. The nut should be snugly seated against the cover plate by finger tightening. The nylon nut must not protrude above the metal surface of the cover plate.
2. Install the filter assembly on the P/N 77852 adapter. Tighten the attaching bolt to 20-25 foot pounds torque. Lockwire the bolt through the loop on the side of the filter housing as shown in Figure 1.
3. Using a P/N 5578426 gasket, install the oil temperature bulb at the location shown in Figures 2 and 3. The hole provided for the oil temperature bulb is tapped 5/8-18 NF-3 to accommodate a P/N MS28034-1 temperature bulb. If a different type is used an adapter may be required.
4. A P/N 53E22144 temperature control oil cooler bypass valve assembly must be assembled at the location provided in the adapter. Use the P/N 76510 gasket that accompanies the valve. See Figures 2, 3 and 4. Lockwire as shown in Figure 1.
5. Start the engine and check for oil leaks. Also check the engine oil; the addition of an oil filter assembly will require adding approximately one quart of oil.

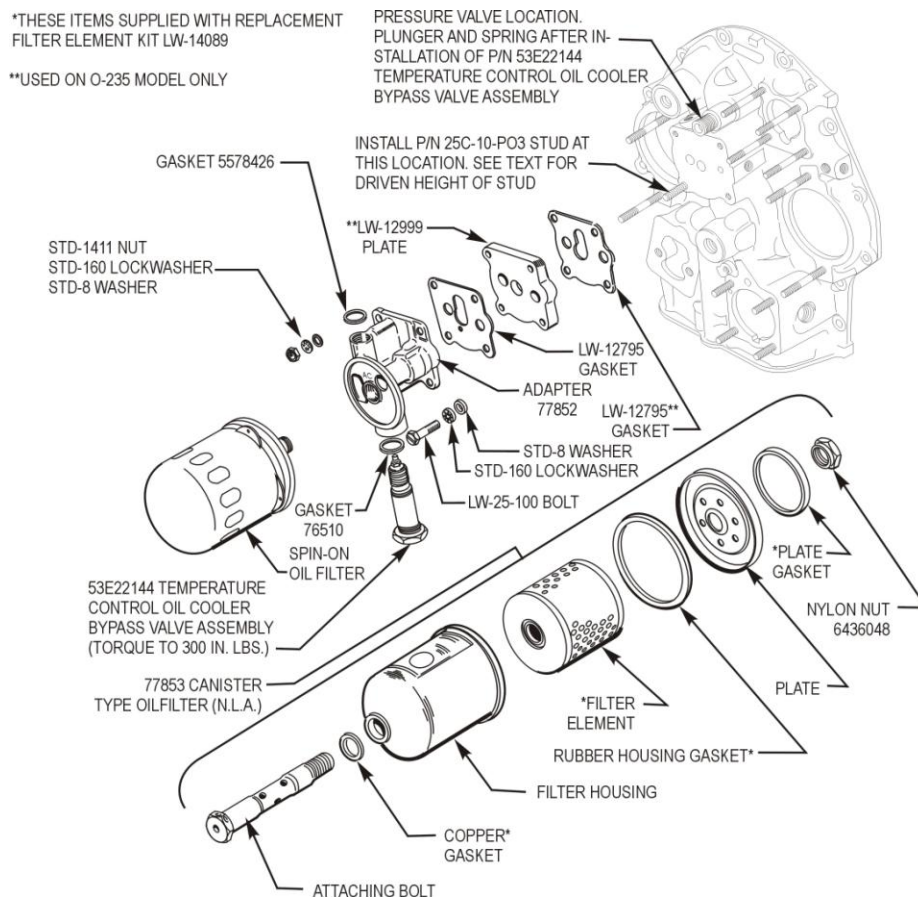

Figure 2. Exploded View of Full-Flow Oil Filter Assembly (O-235)

**PART II – INSTALLATION OF LYCOMING APPROVED FULL-FLOW OIL FILTER ASSEMBLY PART NUMBER LW-14089 (CONT.)**

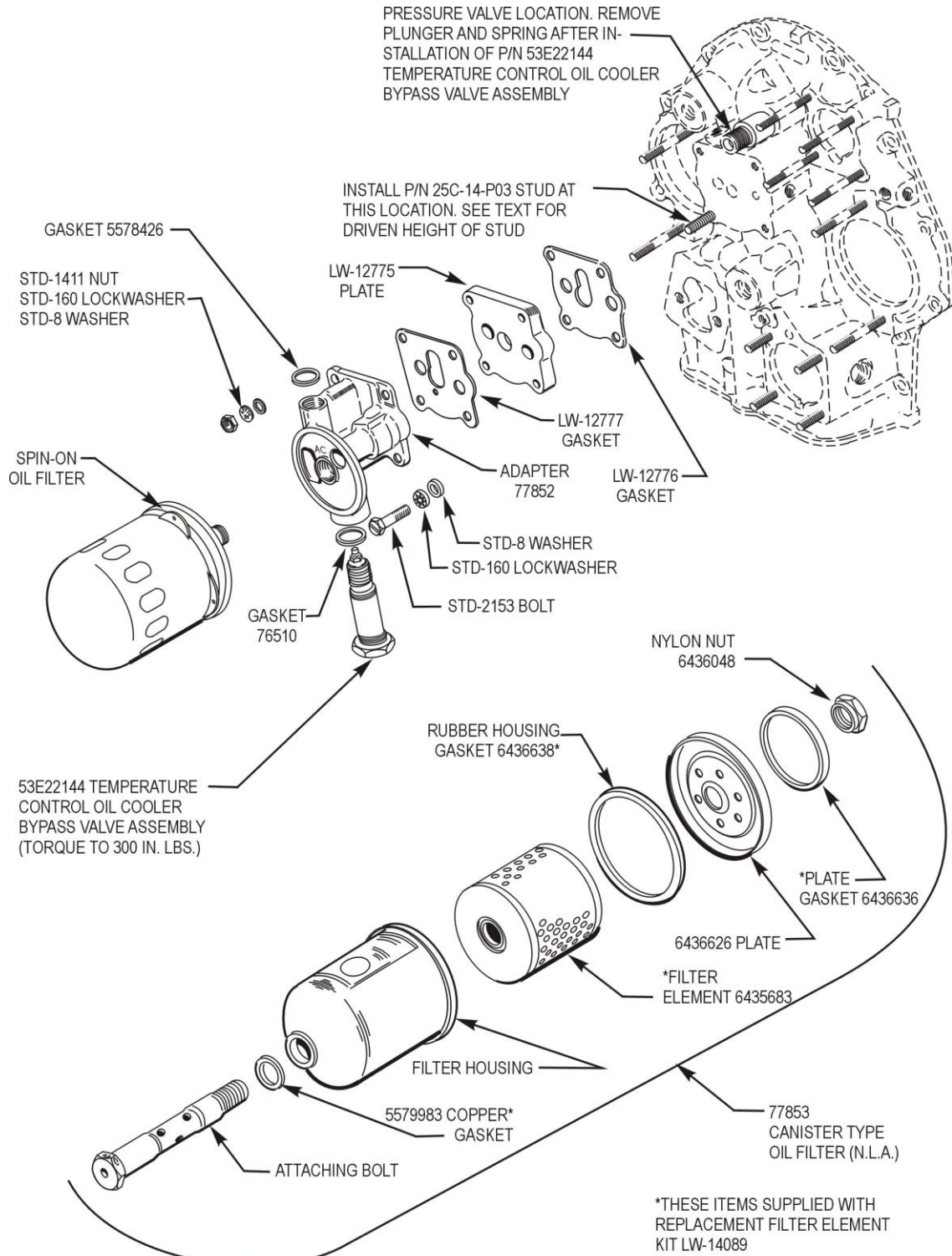

Figure 3. Exploded View of Full-Flow Oil Filter Assembly (IO-720)

**PART III – INSTALLATION OF LYCOMING APPROVED SPIN-ON  
FULL-FLOW OIL FILTER ASSEMBLY**

For the initial installation of a spin-on oil filter on engines with no previous oil filter, proceed with steps 1 through 12 of Part I.

1. Install the spin-on oil filter. Lubricate the oil filter base gasket with Dow Corning – 4 Compound. Follow the filter manufacturers recommended torque specifications.

**CAUTION**

**DO NOT TIGHTEN THE SPIN-ON FILTER BEYOND THE SPECIFIED MAXIMUM TORQUE. OVERTIGHTENING WILL MAKE THE FILTER EXTREMELY DIFFICULT TO REMOVE. ALWAYS USE A 6 POINT SOCKET WHEN TIGHTENING A FILTER INCORPORATING A HEX NUT.**

2. Install the temperature bulb at the location on top of the adapter using a P/N 5578426 gasket. Note that the hole provided for the oil temperature bulb is tapped 5/8-18 NF-3 to accommodate a P/N MS28034-1 temperature bulb. If a different type bulb is used, an adapter may be required.
3. A P/N 53E22144 temperature control oil cooler bypass valve assembly must be assembled at the location provided in the adapter. Use the P/N 76510 gasket that accompanies the valve. See Figures 2, 3 and 4. Lockwire the valve and filter as shown in Figure 1.

**NOTE**

The oil cooler bypass valve mentioned in Part II and Part III is not used on some of the O-235 series engines. On these models use a P/N STD-111 annular gasket and P/N STD-1350 square head plug. Lockwire the plug in the same manner as shown for the thermostatic oil cooler bypass valve in Figure 1.

4. Start the engine and check for oil leaks. Also check the engine oil; the addition of an oil filter assembly will require adding approximately one quart of oil.

The longer length, extra capacity spin-on oil filter has been approved for use on TIO-541 and TIGO-541 series engines. See Part IV of this instruction for additional information. The installation of a Lycoming approved spin-on full-flow oil filter on the TIO-541, TIGO-541, 76 Series and all engines equipped with a Bendix dual magneto requires the addition of the P/N 54E23093 converter plate kit.

The installation of the P/N 54E23093 converter kit is as follows (See Figures 4 and 5):

1. Make sure that the filter mounting base on the engine is clean, smooth and undamaged.
2. Lubricate the gasket of the converter plate with clean engine oil and install it in the filter mounting base.
3. Install the converter stud to hold the plate to the engine. Tighten the stud to 50-60 foot pounds torque.
4. Install the spin-on oil filter. Lubricate the oil filter base gasket with Dow Corning – 4 Compound. Follow the filter manufacturers recommended torque specification.

**NOTE**

It is recommended that the P/N 54E23073 converter plate kit be replaced at engine overhaul.

**CAUTION**

**DO NOT TIGHTEN THE SPIN-ON FILTER BEYOND THE SPECIFIED MAXIMUM TORQUE. OVERTIGHTENING WILL MAKE THE FILTER EXTREMELY DIFFICULT TO REMOVE. ALWAYS USE A 6 POINT SOCKET WHEN TIGHTENING A FILTER INCORPORATING A HEX NUT.**

5. Start the engine and check for oil leaks. If leakage occurs, check the filter and retorque if necessary. Check the converter plate gasket and sealing surface of the engine for damage (cuts, an imperfect gasket, nicks or scratches on the sealing surface).
6. Lockwire the filter to the temperature bulb fitting of the adapter.

**PART III – INSTALLATION OF LYCOMING APPROVED SPIN-ON FULL-FLOW OIL FILTER ASSEMBLY (CONT.)**

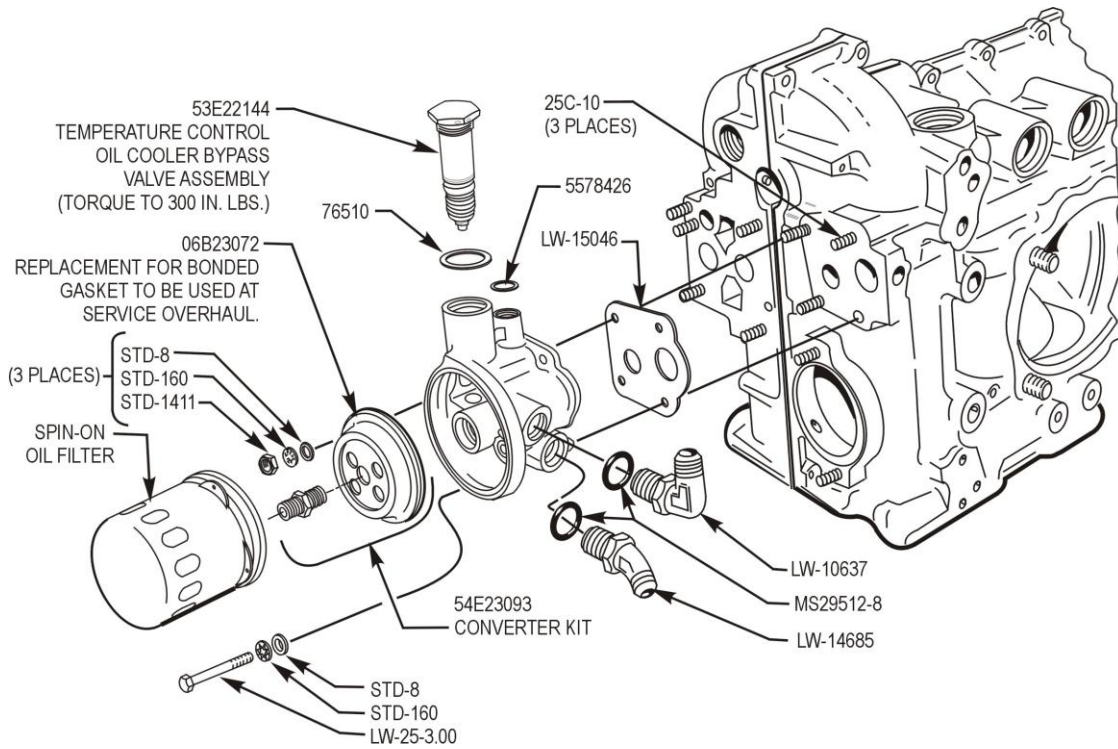

Figure 4. Exploded View of Full-Flow Oil Filter Assembly – 76 Series

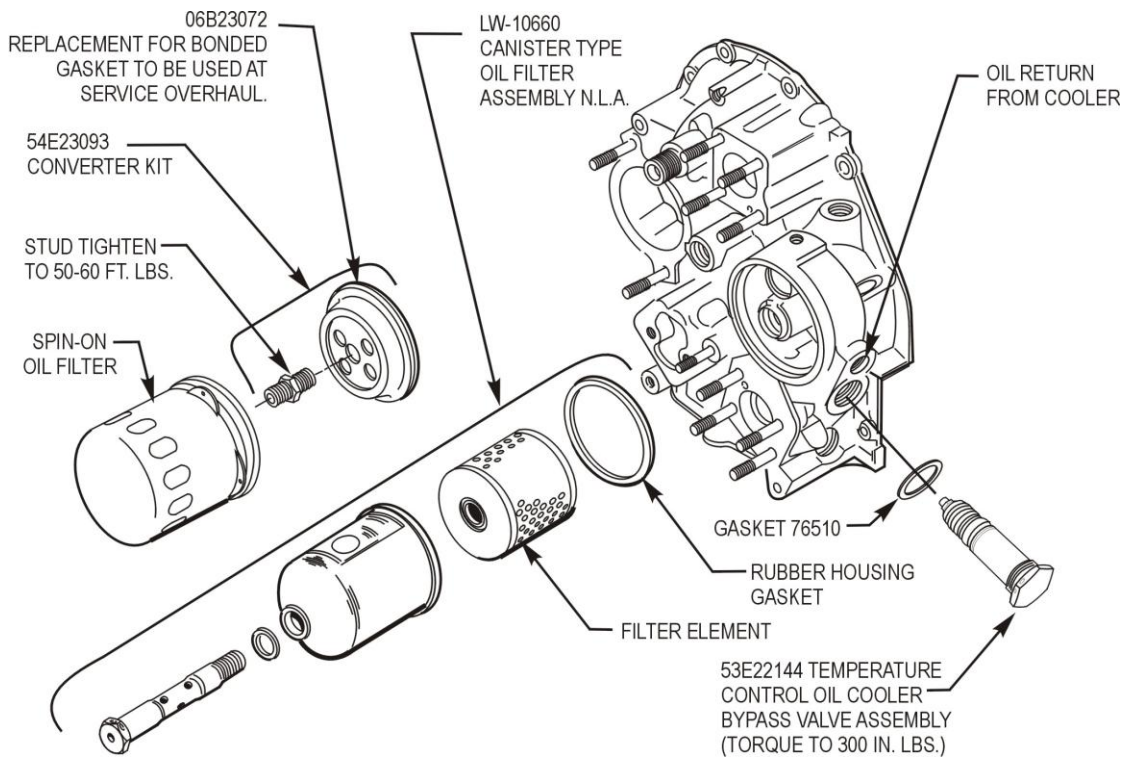

Figure 5. Exploded View of Full-Flow Oil Filter Assembly – Dual Magneto Engines



**PART III – INSTALLATION OF LYCOMING APPROVED SPIN-ON  
FULL-FLOW OIL FILTER ASSEMBLY (CONT.)**

The oil filter element or spin-on filter should normally be replaced each fifty (50) hours of engine operation unless specified otherwise: This is accomplished by removing the lockwire from the filter and removing the filter from the engine.

Before discarding the full-flow filter element, an examination should be achieved by removing the outer perforated paper cover, and using a sharp knife cut through the fold of the element at both ends close to the metal caps. Unfold the pleated element and examine the material trapped in the element for evidence of excessive internal engine wear and damage, such as metal chips or bearing particles. In new or newly overhauled engines some small metallic shavings may be found. These are generally of no consequence and should not be confused with particles produced by impact, abrasion or pressure. Evidence of excessive metal contamination found in the filter element justifies further examination to determine the cause.

To examine the spin-on full-flow filter, Champion Tool No. CT-470 or Airwolf AFC-470 cutter must be used to open the can. Instructions for operating the can opener are as follows:

1. Secure the filter can in a bench vise. When cutting open a female threaded type filter, use the CT-470-2 or AFC-470-2 adapter as illustrated in Figure 6. Male threaded type filters can also be opened with the cutter by removing the CT-470-2 or AFC-470-2 adapter from the rotating bushing.
2. Secure the cutter on the filter mounting plate. Tighten the knurled head screw until the cutter blade meets the metal filter can surface.
3. Rotate the cutter 360° observing that the cutting blade is penetrating the metal can of the filter. Continue tightening the knurled head screw and rotating the cutter until the filter mounting plate is separated from the can.
4. Remove the element from the filter and cut filter material from the end cap. Carefully unfold the element and examine the material trapped in the filter.

After the filter element or spin-on filter has been replaced, properly torqued and lockwired; run the engine and check for oil leaks.

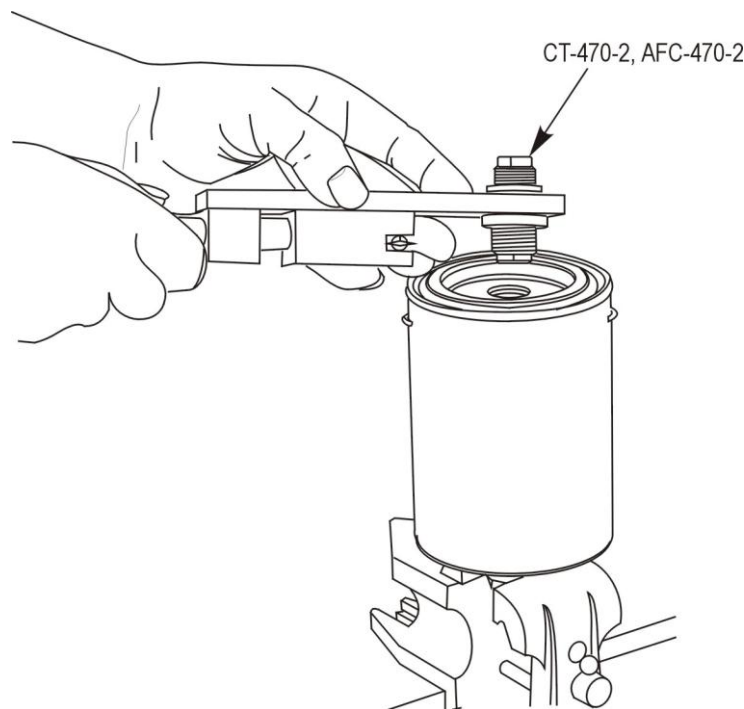

Figure 6. Mounting of Tool – CT-470, AFC-470 on Filter

**PART III – INSTALLATION OF LYCOMING APPROVED SPIN-ON FULL-FLOW OIL FILTER ASSEMBLY (CONT.)**

**NOTE**

Not available for engines with dual magnetos. Hose size requirements are minimum –8, FAA-TSO-C53A, Type “D”. Length of hoses is to be determined at time of installation, depending on location of firewall adapter.

Contact: Lycoming Engines  
652 Oliver Street  
Williamsport, PA 17701 U.S.A.  
Phone: 570-323-6181

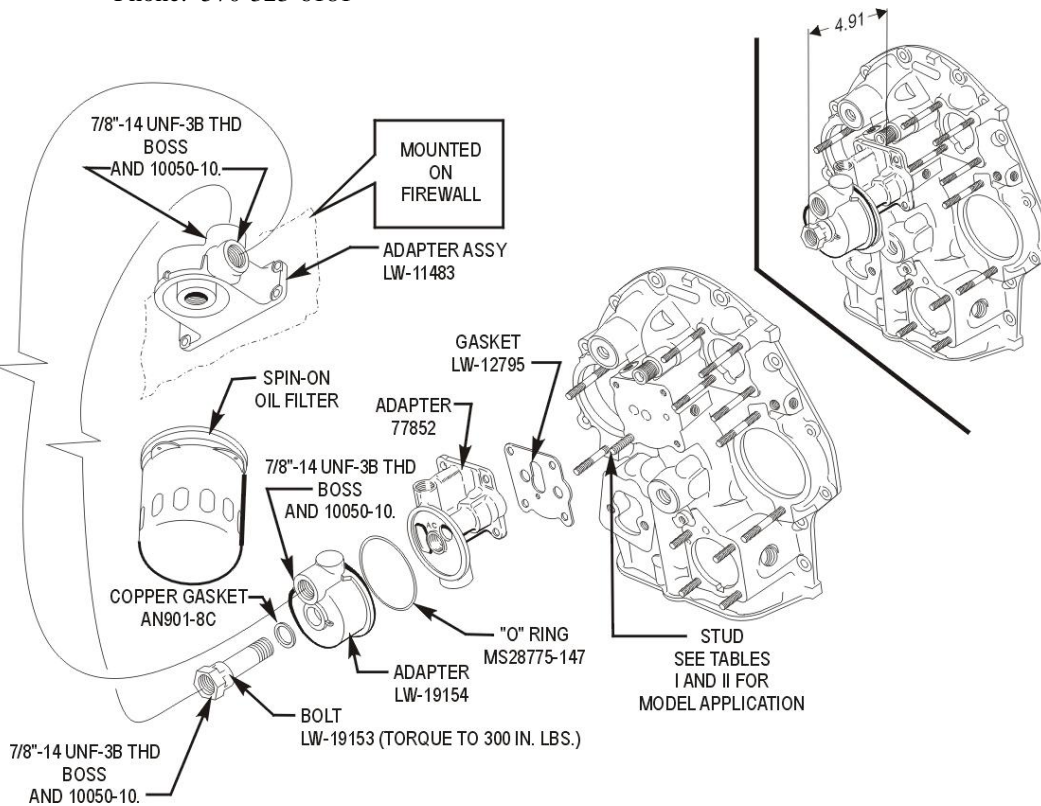

Figure 7. Exploded View of Remote Mounted Oil Filter

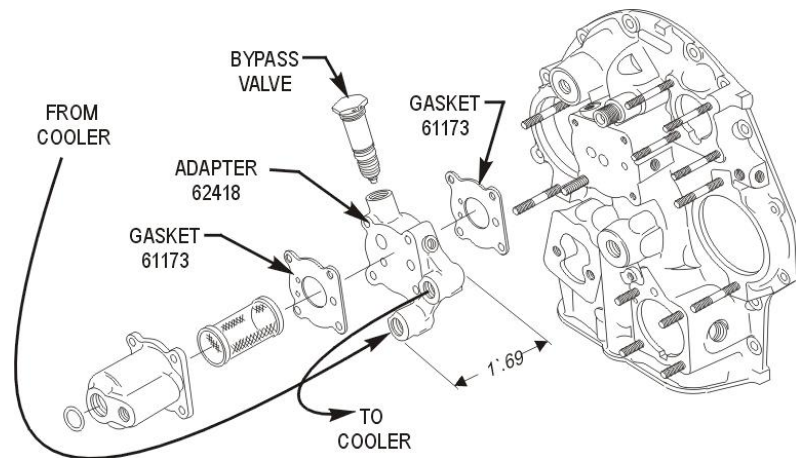

Figure 8. Exploded View of Oil Filtration Screen and Cooler Adapter Assembly

**NOTE**

Used with accessory housing assemblies that do not have the oil cooler line adapter cast in them. Existing attaching hardware for this installation shall be replaced with the following items.

Part No.	Item	Qty.
LW-25-1.00	Screw	4
06E19769-0.63	Gasket	4
STD-8	Washer	4
STD-160	Washer	4

ADDITIONAL REMOTE MOUNTED OIL FILTERS REFERENCE SERVICE INSTRUCTION NO. 1457.

**PART III – INSTALLATION OF LYCOMING APPROVED SPIN-ON  
FULL-FLOW OIL FILTER ASSEMBLY (CONT.)**

**PARTS DATA:**

Table I lists kits available for converting engines from an oil screen housing to a full-flow canister type oil filter. Table II lists kits available for converting engines from an oil screen housing to a spin-on type filter. Oil filter and kit part numbers listed in these tables are those being supplied by Lycoming at publication time of this instruction. Part IV of this instruction lists all Lycoming approved element kits and replacement spin-on filters.

**NOTE**

P/N 77853 canister oil filter housings are exhausted, the canister type filter housing will no longer be available and only the spin-on oil filter kits will be available. Lycoming will, however, continue to supply P/N LW-14089 elements for the P/N 77853 canisters already in the field.

**TABLE I**

**PARTS DATA FOR CONVERSION TO FULL-FLOW  
CANISTER TYPE OIL FILTER  
(REFERENCE ONLY)**

KIT	CONTENTS								APPLICATION
	OIL FILTER ●HOUSING ASSY. ●BASE ASSY.		ADAPTER PLATE		GASKETS		ATTACHING PARTS		
	Part No.	Qty.	Part No.	Qty.	Part No.	Qty.	Part No.	Description Qty.	
75528 NLA Service with LW-13743	*77853 NLA Housing Assy. 77852 Base Assy.		-----	LW-12795 (1) 5578426 (1)		STD-8 Washer (4) STD-1411 Nut (1) 25C-10-P03 Stud (1) LW-25-1.00 Capscrews (3) STD-160 Lockwasher (4)			All applicable engines except O-235; 76 Series; IO-720; TIO-541-E; TIGO-541 and dual magneto models.
75528-1 NLA Service with LW-13744	*77853 NLA Housing Assy. 77852 Base Assy.	LW-12699 (1)		LW-12795 (2) 5578426 (1)		STD-8 Washer (4) STD-1411 Nut (1) 25C-10-P03 Stud (1) LW-25-1.00 Capscrews (3) STD-160 Lockwasher (4)			O-235
75528-2 NLA Service with LW-13745	*77853 NLA Housing Assy. 77852 Base Assy.	LW-12775 (1)		LW-12776 (1) LW-12777 (1) 5578426 (1)		STD-2153 Screw (3) 25C-14-P03 Stud (1) STD-1411 Nut (1) STD-8 Washer (4) STD-160 Lockwasher (4)			IO-720

NOTE: P/N 53E22144 bypass valve assembly not included in the above kits.

\*77853 Oil Filter Housing Assembly includes (1) P/N LW-14089 Replacement Filter Element.

LW-14089 Replacement Filter Element contains (1) P/N 6435683 element, (1) P/N 6436636 square gasket, (1) P/N 5579983 copper gasket and (1) P/N 6436638 flat gasket.

**PART III – INSTALLATION OF LYCOMING APPROVED SPIN-ON  
FULL-FLOW OIL FILTER ASSEMBLY (CONT.)**

**TABLE II  
FOR CONVERSION TO SPIN-ON TYPE OIL FILTER**

KIT PART NO.	CONTENTS										APPLICATION  ENGINE MODEL
	OIL FILTER ASSEMBLY		ADAPTER		ADAPTER PLATE		GASKETS		ATTACHING PARTS		
	Part No.	Qty.	Part No.	Qty.	Part No.	Qty.	Part No.	Qty.	Part No.	Description Qty.	
LW-13743	**LW-13215	(1)	77852	(1)	-----		LW-12795 (1) 5578426 (1)		25C-10-P03 Stud (1) STD-8 Washer (4) STD-160 Lockwasher (4) STD-1411 Nut (1) LW-25-1.00 Capscrew (3)		All applicable engines except O-235;76 Series; IO-720; TIO-541; TIGO-541 and dual magneto engines.
LW-13744	**LW-13215	(1)	77852	(1)	LW-12999	(1)	LW-12795 (2) 5578426 (1)		25C-10-P03 Stud (1) STD-8 Washer (4) STD-160 Lockwasher (4) STD-1411 Nut (1) LW-25-1.00 Capscrew (3)		O-235
LW-13745	**LW-13215	(1)	77852	(1)	LW-12775	(1)	LW-12777 (1) LW-12776 (1) 5578426 (1)		STD-8 Washer (4) STD-160 Lockwasher (4) STD-1411 Nut (4) STD-2153 Screw (3) 25C-14-P03 Stud (1)		IO-720 with -1200 Series Magnetos

NOTE: P/N 53E22144 bypass valve assembly not included in the above kits.

OIL FILTER AND ADAPTER KIT	OIL FILTER ASSEMBLY		ADAPTER ASSEMBLY		CONVERTER PLATE		GASKETS		ATTACHING PARTS		ENGINE MODEL
	Part No.	Qty.	Part No.	Qty.	Part No.	Qty.	Part No.	Qty.	Part No.	Description Qty.	
05K23074	LW-13906	(1)	LW-16118 (1) LW-15047 MS29512-08 LW-10637 LW-14685	(1)	54E23093	(1)	LW-15046 (1) 06E19769-0.63 (1)		STD-8 Washer (4) STD-160 Lockwasher (4) LW-25-3.00 Bolt (1) STD-1411 Nut (3) 25C-10 Stud (3)		O-320-H

\* 05K23074 Kit also contains (1) P/N 53E22144 temperature control oil cooler bypass valve assy., (1) P/N LW-10637 90° elbow, (1) P/N LW-14685 45° elbow and (2) P/N MS29512-8 oil seals for oil cooler installations. O, LO, TO, LTO-360-E series engines and engines with a dual magneto accessory housing are shipped with oil filter installed. No oil filter kits are available for these engines.

\*\* For alternate oil filter assemblies see page 11.

**PART IV – APPROVED OIL FILTER ELEMENT KITS AND SPIN-ON OIL FILTERS**

NOTE

The following sources market Lycoming approved full-flow filter element kits and spin-on filters.

FULL-FLOW FILTER ELEMENT KITS

O-235; O, IO, LIO, AEIO-320; O, IO, LIO, HIO, TIO, AEIO-360; O, IO, TIO, LTIO, AEIO-540 and TIO-541-A series engines use any of the following kits available through Lycoming distributors as P/N LW-14089.

AC Spark Plug Division .....Type OF-11A P/N 6435683  
 Champion Spark Plug Company..... P/N CFO-100  
 Facet Enterprises (FRAM)..... P/N CH-507-PL  
 Winslow Filter Corp. .... P/N 1A 0920

TIO-541-E and TIGO-541 series engines use any of the following kits available through Lycoming distributors as P/N LW-11198.

CAUTION

THE P/N LW-11198 FILTER KIT CONTAINS AN MS-9021-154 OR MS-29513-154 “O” RING SEAL WHICH MUST BE INSTALLED BETWEEN THE FILTER BASE AND THE HOUSING. IF THIS “O” RING SEAL IS NOT SUPPLIED WITH THE OIL FILTER ELEMENT KIT, IT MUST BE PROCURED SEPARATELY. DO NOT ATTEMPT TO SUBSTITUTE ANY OTHER SEAL AT THIS LOCATION: LOSS OF LUBRICATING OIL AND SUBSEQUENT ENGINE DAMAGE CAN RESULT. SEE THE LATEST REVISION OF LYCOMING SERVICE BULLETIN NO. 397 FOR DETAILED INFORMATION.

AC Spark Plug Division .....Type OF-6A P/N 5579799  
 Champion Spark Plug Company..... P/N CFO-101  
 Facet Enterprises (FRAM)..... P/N CH-506-PL  
 Winslow Filter Corp. .... P/N 1A 0525

CAUTION

DO NOT USE ANY TYPE OF-6A P/N 5579799 FILTER DATED PRIOR TO AUGUST 14, 1970.

**SPIN-ON FILTERS WITH STUD INSTALLED**

**For use on O-235; O, IO, LIO, AEIO-320; O, IO, LIO, HIO, TIO, AEIO-360;  
 O, IO, TIO, LTIO, AEIO-540 and TIO-541-A series engines.**

The filter length is listed as an aid in filter installation. When determining the total length of a filter and stud assembly, add 11/16 inch to the listed dimension.

Lycoming Part No.	Vendor	Vendor Part No.	Filter Length
*LW-16458	AC Spark Plug Division		4.28
LW-13215	Champion Spark Plug Co.	CH-48110	4.75
**LW-16459	AC Spark Plug Division		5.90
LW-13216	Champion Spark Plug Co.	CH-48111	5.75

\* LW-16458 filter assembly contains (1) Type OF-51A P/N AC25010539 filter and (1) Type OF-712 P/N AC25010628 stud.  
 \*\* LW-16459 filter assembly contains (1) Type OF-61A P/N AC25010623 filter and (1) Type OF-712 P/N AC25010628 stud.

**PART IV – APPROVED OIL FILTER ELEMENT KITS AND SPIN-ON OIL FILTERS**

**SPIN-ON FILTERS WITHOUT STUD INSTALLED**  
**For use on TIO-541-E, TIGO-541 and engines with dual magnetos.**  
**Requires 1 P/N 54E23093 converter plate.**

<b>Lycoming Part No.</b>	<b>Vendor</b>	<b>Vendor Part No.</b>	<b>Filter Length</b>
LW-16286	AC Spark Plug Division	Type OF-51A AC25010539	4.28
LW-13906	Champion Spark Plug Co.	CH-48103	4.75
LW-16287	AC Spark Plug Division	Type OF-61A AC25010623	5.90
LW-13905	Champion Spark Plug Co.	CH-48104	6.12